

DSEULTRA[®] STARTING WITH QUALITY.

DSE705 & DSE4130 AUTO TRANSFER SWITCH CONTROL MODULES



SPECIFICATION

DC SUPPLY

8V to 35V continuous

CRANKING DROPOUTS

Able to survive 0V for 50mS, providing supply was at least 10V before dropout and supply recovers to 5V. This is achieved without the need for internal batteries.

MAXIMUM OPERATING CURRENT

50mA(12V and 24V) (DSE4130 only)
50mA (DSE705 only)

TYPICAL CURRENT

15mA(12V and 24V) (DSE4130 only)
12mA (DSE705 only)

ALTERNATOR INPUT RANGE

75V(L-N) to 333V AC (L-N) absolute maximum

ALTERNATOR INPUT FREQUENCY

50Hz – 60Hz at rated engine speed
(minimum:75V AC L-N)

START & RUN OUTPUTS

1.2 Amp DC at supply voltage. Switches to battery negative when active

CLOSE GEN/MAINS CONTROL OUTPUTS

1.2 Amp DC at supply voltage. Switches to battery negative when active

AUXILIARY OUTPUTS

1.2 Amp DC at supply voltage. Switches to battery negative when active

DSE705 DIMENSIONS

165mm x 125mm x 29mm
6.5" x 4.9" x 1.2"

DSE705 CUT OUT

149mm X 109mm
5.9" x 4.3"

DSE4130 DIMENSIONS

171mm x 115mm x 49mm
6.75" x 4.5" x 2"

DSE4130 CUT OUT

154mm x 98mm
6.1" x 3.9"

ENVIRONMENTAL TESTING STANDARDS

ELECTRO MAGNETIC CAPABILITY

BS EN 61000-6-2
EMC Generic Emission Standard for the Industrial Environment
BS EN 61000-6-4
EMC Generic Emission Standard for the Industrial Environment

TEMPERATURE

BS EN 60068-2-2
Test Ab to +70°C 60067-2-2 Hot
Test Ab to -30°C 60068-2-1 Cold

VIBRATION

BS EN 60068-2-6
Ten sweeps in each of three major axes
5Hz to 8Hz @ +/-7.5mm, 8Hz to 500Hz @ 2gn

HUMIDITY

BS 2011 part 2.1 60068-2-30
Test Cb Ob Cyclic
93% RH @ 40°C for 48 hours

SHOCK

BS EN 60068-2-27
Three shocks in each of three major axes
15gn in 11mS

DSE705

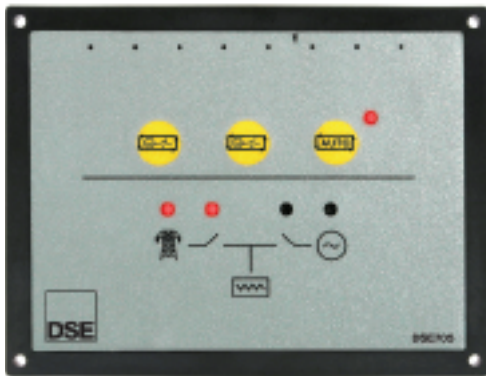

DSE4130

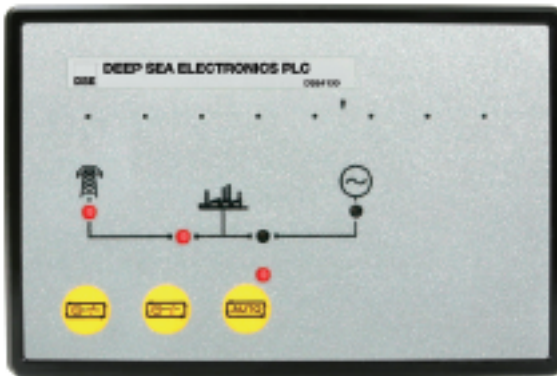

The DSE705 and DSE4130 are Auto Transfer Switch Control Modules that have been designed to monitor the mains (utility) supply.

When the mains (utility) power fails the modules send a start request to the generator control unit.

When the generator is up and running the modules transfer the load across. When the mains (utility) returns, the modules transfer the load back and remove the start command. The generator should then begin its shutdown procedure.

Both modules can be configured so that they follow the users pre-set start and stop sequences. The DSE4130 enclosure has a closed back.

FEATURES

- Automatic mains (utility) supply monitoring
- Load changeover control
- Manual start
- Protected Solid State (PSS) outputs
- Front panel mounting
- Front panel programming
- LED indicators
- Configurable timers
- Configurable outputs
- Single/three phase mains sensing
- Remote start input

BENEFITS

- Transfers between mains and generator power
- On-site module configuration to match user requirements

OPERATION

The modules are operated using the three push buttons on the front:



MANUAL OFF LOAD -

This is used to manually start and run the engine off load. Should the mains (utility) supply fail, then the load is transferred to the generator automatically.



MANUAL ON LOAD -

This mode is used to manually start and run the engine on load.



AUTO MODE - This puts the module into automatic mode, where it will await a mains (utility) failure. Upon detection it will send a start request to the generator control unit.

DEEP SEA ELECTRONICS PLC

Highfield House
Hunmanby Industrial Estate
Hunmanby, North Yorkshire
YO14 0PH England

TELEPHONE

+44 (0)1723 890099

FACSIMILE

+44 (0)1723 893303

EMAIL

sales@deepseapl.com

WEBSITE

www.deepseapl.com

Registered in England & Wales No.01319649

VAT No.316923457

DEEP SEA ELECTRONICS INC

3230 Williams Avenue
Rockford
IL 61101-2668 USA

TELEPHONE

+1 (815) 316 8706

FACSIMILE

+1 (815) 316 8708

EMAIL

sales@deepseausa.com

WEBSITE

www.deepseausa.com

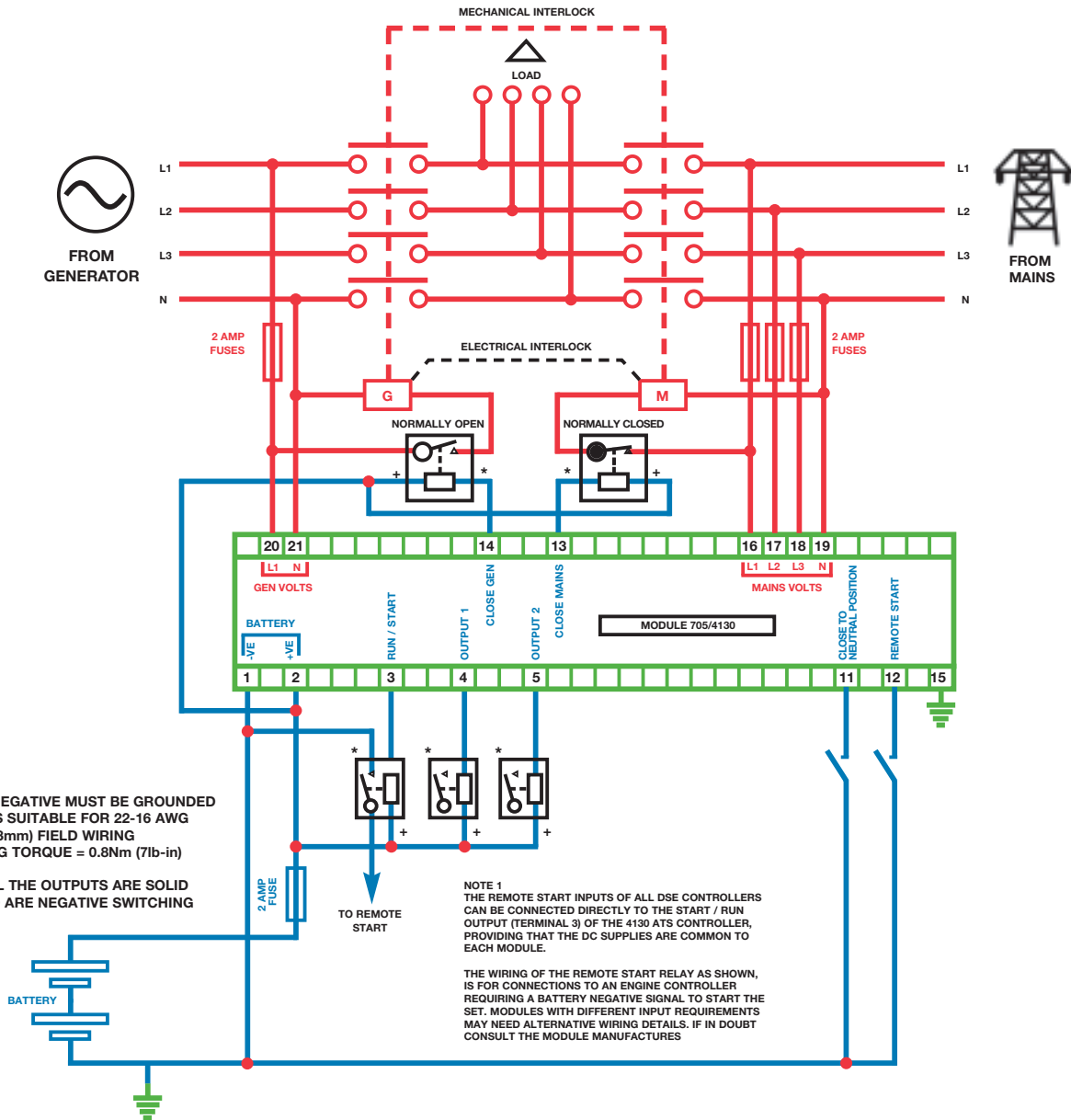

DSE705 & DSE4130

**CONFIGURATION**

The modules can be configured to match user's individual parameter settings. Configuration mode is accessed via the switch at the rear of the module. Once in configuration mode the **AUTO-LED** flashes rapidly.

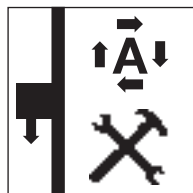

NORMAL

CONFIGURATION

RELATED MATERIALS

TITLE	PART NO'S
DSE705 Installation Instructions	053-037
DSE705 Operators Manual	057-044
DSE4130 Installation Instructions	053-024
DSE4130 Operators Manual	057-024

Please refer to the installation instructions for the parameter settings and full configuration information.

DEEP SEA ELECTRONICS PLC maintains a policy of continuous development and reserves the right to change the details shown on this data sheet without prior notice. The contents are intended for guidance only.

This data sheet is printed on 9lives 55 Silk, which is produced with 55% recycled fibre from both pre and post-consumer sources, together with 45% virgin ECF fibre.

