

TYPICAL WIRING DIAGRAM

NOTE: A larger version of the Typical Wiring Diagram is available in the product's operator manual, refer to DSE Publication: 057-361 DSE2160 Operator Manual available from www.deepseaelectronics.com for more information.

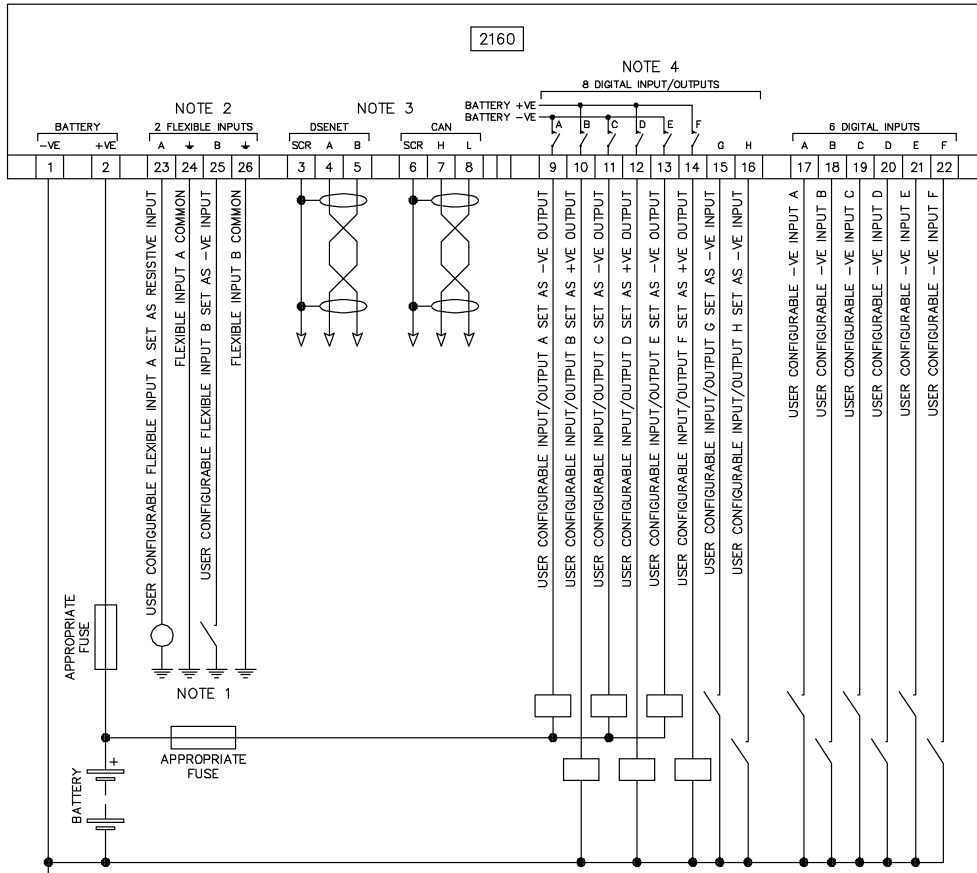

BATTERY NEGATIVE MUST BE GROUND

NOTE 1. THESE GROUND CONNECTIONS MUST BE ON THE ENGINE BLOCK, AND MUST BE TO THE SENSOR BODIES.

NOTE 2. THE 2 FLEXIBLE INPUTS ARE INDIVIDUALLY CONFIGURABLE AS -VE DIGITAL INPUT OR RESISTIVE INPUT

NOTE 3. IF THE MODULE IS FIRST OR LAST UNIT ON THE LINK, IT MUST BE FITTED WITH A 120 OHM TERMINATION RESISTOR ACROSS TERMINALS A AND B FOR DSENET OR H AND L FOR CAN.

NOTE 4. THE 8 DIGITAL INPUT/OUTPUTS ARE INDIVIDUALLY CONFIGURABLE AS -VE DIGITAL INPUT, -VE DIGITAL OUTPUT. OR +VE DIGITAL OUTPUT.

Deep Sea Electronics Ltd.

Tel: +44 (0)1723 890099

Email: support@deepseaelectronics.com

Web: www.deepseaelectronics.com

Deep Sea Electronics Inc.

Tel: +1 (815) 316 8706

Email: support@deepseaelectronics.com

Web: www.deepseaelectronics.com



DEEP SEA ELECTRONICS

DSE2160 Installation Instructions

053-268

ISSUE 1

This document details the installation requirements of the DSE2160 Input and Output Expansion Module and is part of the DSEgenset® range of products.

The DSE2160 Input and Output Expansion module is designed to enhance the input capabilities of supported DSE modules. The module offers 8 Digital Input/Outputs, 6 Digital Inputs and 2 Analogue inputs. The configuration of the expansion module is done within the host module's configuration. The only configuration applied to DSE2160 is the selection of the ID switch to match the host module's configuration.

CONTROLS AND INDICATION

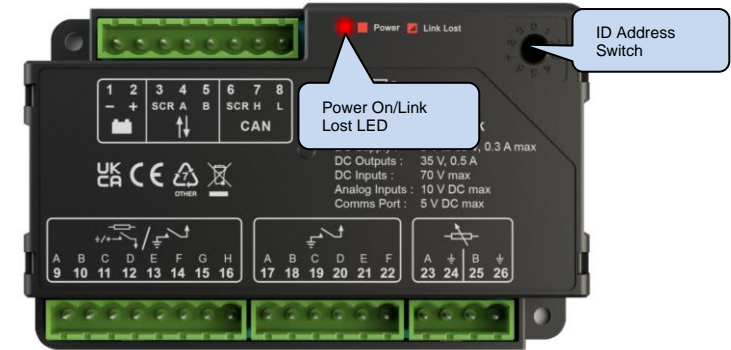

STATUS LED

The Status LED indicates the operating state of the module.

Status LED	Condition
Off	Module is not powered.
Red Flashing	Module is powered but there is no communication.
Red Constant	Module is powered and communication is working.

ID SWITCH

The DSENet ID Rotary Selector selects the communication ID that the module uses for DSENet or the source address that the module uses for CAN, as it is capable of being connected to multiple DSE2160 modules/devices at the same time. The DSENet® ID rotary switch must be operated using an isolated adjustment tool.

NOTE: The DSENet® ID be set to be a unique number compared to any other DSE2160. The DSENet® ID of the DSE2160 does not interfere with the DSENet® ID of any other type of expansion module. For instance it's OK to have a DSE2160 with a DSENet® ID of 1 and a DSE2170 with a DSENet® ID of 1.

POWER SUPPLY REQUIREMENTS

Description	Specification
Minimum Supply Voltage	8 V continuous
Cranking Dropouts	Able to survive 0 V for 50 ms providing the supply was at least greater than 10 V for 2 seconds before the dropout and recovers to 5 V afterwards.
Maximum Supply Voltage	35 V continuous (60 V protection)
Reverse Polarity Protection	-35 V continuous
Maximum Operating Current	190 mA at 12 V 90 mA at 24 V
Maximum Standby Current	110 mA at 12 V 50 mA at 24 V

USER CONNECTIONS

DC SUPPLY, DSENET® & RS485

	Pin No	Description	Cable Size	Notes
	1	DC Plant Supply Input (Negative)	2.5 mm ² AWG 13	Connect to ground where applicable.
	2	DC Plant Supply Input (Positive)	2.5 mm ² AWG 13	Supplies the module and Digital Outputs
	3	DSENET® Expansion Screen	Shield	Use only 120 Ω CAN or RS485 approved cable
	4	DSENET® Expansion A	0.5 mm ² AWG 20	
	5	DSENET® Expansion B	0.5 mm ² AWG 20	
CAN	6	CAN Screen	Shield	Use only 120 Ω CAN or RS485 approved cable
	7	CAN H	0.5 mm ² AWG 20	
	8	CAN L	0.5 mm ² AWG 20	

DIGITAL INPUT/OUTPUTS

	Pin No	Description	Cable Size	Notes	
	9	Digital Input/Output A	1.0mm ² AWG 18	When configured as a digital output, switches module supply positive or negative depending on configuration.	
	10	Digital Input/Output B	1.0mm ² AWG 18		
	11	Digital Input/Output C	1.0mm ² AWG 18		
	12	Digital Input/Output D	1.0mm ² AWG 18		
		13	Digital Input/Output E	1.0mm ² AWG 18	When configured as digital input, switch to negative.
		14	Digital Input/Output F	1.0mm ² AWG 18	
		15	Digital Input/Output G	1.0mm ² AWG 18	
		16	Digital Input/Output H	1.0mm ² AWG 18	

DIGITAL INPUTS

	NOTE: DC Input A (Terminal 17) offers various modes of input. 1. Digital input mode: Functions similarly to Connector B (Terminals 10-16). 2. Pulse counting mode: Primarily designed for tallying the output generated by gas meters and similar devices. 3. Frequency measurement mode: Enables the measurement of frequencies ranging from 5Hz to 10kHz.
--	--

	Pin No	Description	Cable Size	Notes
	17	Digital/High Frequency Input A	1.0mm ² AWG 18	Switch to negative.
	18	Digital Input B	1.0mm ² AWG 18	
	19	Digital Input C	1.0mm ² AWG 18	
	20	Digital Input D	1.0mm ² AWG 18	
	21	Digital Input E	1.0mm ² AWG 18	
	22	Digital Input F	1.0mm ² AWG 18	

ANALOGUE INPUTS

	NOTE: It is VERY important that terminals 24 and 26 (sensor common) are connected to an earth point on the ENGINE BLOCK, not within the control panel, and must be a sound electrical connection to the sensor bodies. This connection MUST NOT be used to provide an earth connection for other terminals or devices. The simplest way to achieve this is to run a SEPARATE earth connection from the system earth star point to terminal 24 and 26 directly, and not use this earth for other connections.
--	--

	NOTE: If PTFE insulating tape is used on the sensor thread when using earth return sensors, ensure not to insulate the entire thread, as this prevents the sensor body from being earthed via the engine block.
--	---

	Pin No	Description	Cable Size	Notes
	23	Analogue Input A	0.5 mm ² AWG 20	Connect to the output of the sensor.
	24	Analogue Input A Return	0.5 mm ² AWG 20	Ground return feed for Analogue Input A.
	25	Analogue Input B	0.5mm ² AWG 20	Connect to the output of the sensor.
	26	Analogue Input B Return	0.5 mm ² AWG 20	Ground return feed for Analogue Input B.

REQUIREMENTS FOR UL

Specification	Description
Screw Terminal Tightening Torque	<ul style="list-style-type: none"> 4.5 lb-in (0.5 Nm)
Conductors	<ul style="list-style-type: none"> Terminals suitable for connection of conductor size 13 AWG to 20 AWG (0.5 mm² to 2.5 mm²). Conductor protection must be provided in accordance with NFPA 70, Article 240 (USA). Low voltage circuits (35 V or less) must be supplied from the engine starting battery or an isolated secondary circuit and protected by a Listed fuse rated max. 2A. The communication, sensor, and/or battery derived circuit conductors shall be separated and secured to maintain at least 1/4" (6 mm) separation from the generator and mains connected circuit conductors unless all conductors are rated 600 V or greater. Use only copper conductors rated for a minimum operating temperature of 158 °F (70 °C).
Communication Circuits	<ul style="list-style-type: none"> Must be connected to communication circuits of UL Listed equipment (if working to UL requirements).
DC Output	<ul style="list-style-type: none"> The current pilot duty of the DC outputs is not rated. The DC outputs must not be used for control of a fuel safety valve.
Mounting	<ul style="list-style-type: none"> The device shall be installed within an unventilated Type 1 enclosure minimum, or ventilated Type 1 enclosure minimum provided with filters to maintain a pollution degree 2 or controlled environment. For flat surface mounting in Type 1 Enclosure Type rating provided with filters to maintain a pollution degree 2 or controlled environment. Surrounding air temperature -22 °F to +158 °F (-30 °C to +70 °C).

DIMENSIONS AND MOUNTING

Parameter	Specification
Overall size	120 mm x 75 mm x 31.5 mm (4.72" x 2.95" x 1.24")
Weight	200 g (0.44 lb)
Mounting type	DIN rail or chassis mounting
Din rail type	EN 50022 35mm type only
Mounting holes	M4 clearance
Mounting hole centres	108 mm x 63 mm (4.25" x 2.48")