

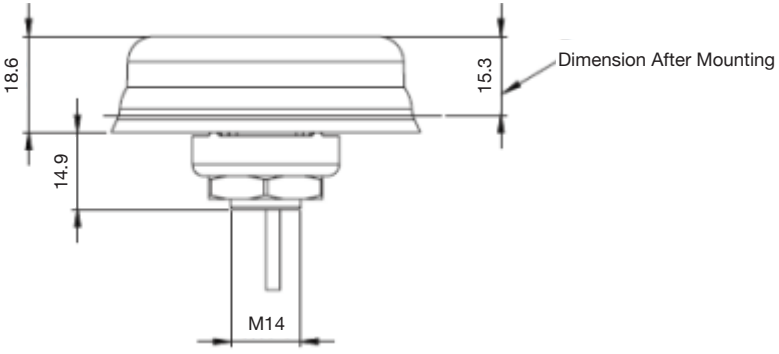

# 020-1079

## GPS Antenna SMA(M) 3m cable



<b>TYPE</b>	GPS Antenna
<b>FREQUENCIES</b>	GPS/GLONASS/QZSS/Galileo - 1575 - 1606 MHz
<b>MOUNTING</b>	Screw Mount
<b>PROTECTION</b>	IP67/IP69K
<b>OPERATING TEMPERATURE</b>	-40 °C to +85 °C -40 °F to +185 °F
<b>MATERIAL</b>	Housing – ABS Base – Zamak
<b>MAXIMUM DIMENSIONS</b>	<p><b>Diameter</b> 60 mm 2.36"</p> <p><b>Housing depth</b> 15.3 mm 0.60"</p> 
<b>WEIGHT</b> (Based on default cable length & connector)	200 g 7.05 oz
<b>COLOUR</b>	Black



### DEEP SEA ELECTRONICS LTD

Highfield House, Hunmanby Industrial Estate, Hunmanby YO14 0PH  
**TELEPHONE** +44 (0) 1723 890099 **FACSIMILE** +44 (0) 1723 893303  
**EMAIL** sales@deepseaelectronics.com **WEBSITE** www.deepseaelectronics.com

Deep Sea Electronics Ltd maintains a policy of continuous development and reserves the right to change the details shown on this data sheet without prior notice. The contents are intended for guidance only.

### DEEP SEA ELECTRONICS INC

3230 Williams Avenue, Rockford, IL 61101-2668 USA  
**TELEPHONE** +1 (815) 316 8706 **FACSIMILE** +1 (815) 316 8708  
**EMAIL** usasales@deepseaelectronics.com **WEBSITE** www.deepseaelectronics.com

Registered in England & Wales No.01319649  
VAT No.316923457