



FEATURES

- 'Basic' module provides a number of control and monitoring features with expansion capability to meet demanding specifications. The ideal choice where a remote communications control system is specified (when used with one of the comms output options below).
- 'Enhanced power measurement' module provides all the functions of the 'Basic' unit but also includes full power monitoring instrumentation (detailed right) and powerful auto-sync functions as standard. The inclusion of auto-sync now allows the OEM to offer the choice of clean break or 'Bumpless' no break transfers to and from the gen-set. No need for complex sync panels etc. Simply use the 555 Power measurement module and interface to the engine governor and AVR. (No break transfer using the 555 module requires connecting to a suitable electronic governor and AVR.)
- Load control versions can be used to export a fixed amount of power to the load while in parallel with the mains, with soft transfer to and from the gen-set.
- Optional RS232 port allows comprehensive remote control and monitoring. RS232 provides modem link to PC via PSTN line or GSM network (with suitable modem). Uniquely, the module supplies DC power to the modem ensuring integrity of link during loss of mains and engine starting. The module can also signal Engineers via the cell phone network using the GSM SMS messaging system to advise of system alarms.
- Optional RS485 'Modbus' output. Using industry standard communication protocol allows full system integration into new and existing building management and control schemes.

The 500 series modules have been designed for **front panel mounting**. The module is fitted into the cut-out with the fixing clips removed. These are then fitted from the rear. Connection is via locking plug and socket connectors.

DESCRIPTION

The Model 555 is an **Automatic Mains Failure Control Module**, with comprehensive instrumentation and **load control option**. The module is used to monitor a mains supply and automatically start and stop the engine. It indicates the operational status and fault conditions, automatically shutting down the engine and indicating engine failure by means of an LCD display, and flashing LED on the front panel.

Selected operational sequences, timers and alarms can be altered by the customer. Alterations to the system are made using the 810 interface and a PC. This interface also provides real time diagnostic facilities.

It is also possible to monitor the operation of the system either locally or remotely (Optional: Remote Communications output version only). Access to the module is restricted by PIN number.

Operation of the module is via **pushbutton controls** (with security locking facility) mounted on the front panel with STOP/RESET, AUTO, TEST, MANUAL and START functions. The first four pushbuttons feature LED 'selected' indications. Further pushbuttons provide MUTE/LAMP TEST, LCD PAGE and DISPLAY SCROLL functions.

The module features 32-Bit Microprocessor control and a comprehensive list of timers and pre-configured sequences. User configurable expansion facilities are also provided.

The 555 module provides **metering and alarm facilities** via the LCD display with the following instrumentation displays, accessed via the LCD PAGE and DISPLAY SCROLL push-buttons:

- Generator Volts L1-N, L2-N, L3-N
- Generator Volts L1-L2, L2-L3, L3-L1
- Generator Amps L1,L2,L3
- Generator Frequency Hz
- Mains Volts L1-N, L2-N, L3-N
- Mains Volts L1-L2, L2-L3, L3-L1
- Mains Frequency Hz
- Engine Speed RPM
- Engine Oil Pressure
- Engine Temperature
- Plant battery Volts
- Engine Hours Run
- Number of Start Attempts
- Remaining Time until Maintenance



OPTIONAL FEATURES on Power Measurement version only:

- Generator kVA L1,L2,L3, Total
- Generator kW L1,L2,L3, Total
- Generator pf L1,L2,L3,Average
- Generator kVAh L1,L2,L3, Total
- Generator KWh
- Generator KVAh
- Generator KVAh
- Generator Phase Sequence
- Synchroscope Display

The instrumentation displays are supplemented further by **LCD display pages** covering operating status and alarms. The selected page is displayed along with an LED tell-tale:

- Status Page
- Alarm Page
- Engine Instruments Page
- Generator Instruments Page
- Mains Instruments Page
- Event Log Page

**LED indication** is provided for Alarm present.

Four uncommitted LED's allow the user to configure the module to provide other status indications from either internal states or from external digital inputs.

Description continues overleaf...

## DESCRIPTION CONTINUED

The module accepts the following **digital inputs**:

- Emergency Stop Input - A N/C DC positive input
- 9 fully configurable warning or shutdown inputs

With the exception of the Emergency Stop Input, these are configurable to be either N/C or N/O contacts connected to the -Ve DC. The nine fully configurable auxiliary inputs can be selected to be indication, warning or shutdown inputs, either immediate or held off during start up, to allow for use as protection expansion inputs. Alternatively they may be configured to control extra functions such as manual load switching, Lamp Test or Remote Start input, Generator Start signal and many others.

**Engine analogue inputs** are provided for Oil Pressure and Engine Temperature. These connect to conventional engine-mounted resistive sender units (such as VDO or Datcom Type) to provide accurate monitoring and protection facilities. Alternatively they can be configured to interface with digital switch-type inputs for Low Oil Pressure and High Engine Temperature shutdowns.

**Relay outputs** are provided for Fuel Solenoid, Start and four configurable outputs. The configurable relay functions can be selected from a range of 100+ different functions, conditions or alarms. The relays supply positive plant supply out. Additional output relays can be added by means of up to two 157 Relay Expansion Modules. A total of 20 outputs are available with full expansion of the 555 Module. This allows the module system to be incorporated into existing telemetry or Building Management Schemes via volt-free contacts.

*Refer to appropriate manuals for details.*

**Multiple alarm channels** are provided to monitor the following:

- Under/Over Generator Volts
- Over-current
- Under/Over Generator Frequency
- Under/Overspeed
- Charge Fail
- Emergency Stop
- Low Oil Pressure
- High Engine Temperature
- Fail to Start
- Low/High DC Battery Volts
- Fail to come to rest
- Reverse Power (*'Power Measurement' Version only*)

- Generator Phase rotation error (*'PM' Version only*)
- Generator Short Circuit Protection (*'PM' Version only*)
- Loss of speed sensing signal
- Mains out of limits
- Mains Phase rotation error
- Fail to Synchronise
- MPU Open circuit failure along with any configurable input alarms as selected. Alarms are indicated by an LCD Message, LED illumination and Audible Alarm.

## SPECIFICATION

### DC Supply:

8 to 35 V Continuous.

### Cranking Dropouts:

Able to survive 0 V for 50 mS, providing supply was at least 10 V before dropout and supply recovers to 5V. *This is achieved without the need for internal batteries.*

### Max. Operating Current:

513mA at 12 V. 263 mA at 24 V.

### Max. Standby Current:

370 mA at 12 V. 210 mA at 24 V.

### Alternator Input Range:

15 V(ph-N) to 277 V(ph-N) AC (+20%)

### Alternator Input Frequency:

50 - 60 Hz at rated engine speed (Minimum: 15V AC Ph-N)

### Magnetic Pick-up Voltage Input Range:

+/- 0.5 V to 70 V Peak

**Magnetic Input Frequency:** 10,000 Hz (max)

### Mains Sensing Input Range:

15V(ph-N) to 277V(ph-N) AC (+20%)

### Mains Sensing Input Frequency:

50 - 60 Hz at rated engine speed (Minimum: 15V AC Ph-N)

### Start Relay Output:

16 Amp DC at supply voltage.

### Fuel Relay Output:

16 Amp DC at supply voltage.

### Auxiliary Relay Outputs:

5 Amp DC at supply voltage.

### Generator loading Relay Output:

8 Amp AC 250V.

### Mains loading Relay Output:

8 Amp AC 250V

### Charge Fail / Excitation Range:

0 V to 35 V

### Operating Temperature Range:

-30 to +70°C

### Dimensions:

192mm x 144mm x 138mm  
7.6" x 5.7" x 5.5"

## TIMERS AND INPUT FUNCTIONS

- Start delay timer
- Stop delay timer
- Crank/Crank Rest timers
- Engage Attempt and Manual Crank Limit timers
- Safety On delay timer
- Warm-up timer
- Cooling timer
- Energise to Stop hold timer
- Pre-heat timer / Pre-heat bypass timer
- Smoke Limiting control timers
- Fail to Come to Rest timer
- Over-speed Overshoot timer
- Breaker Pulse control timers
- DC Battery alarm delay timers

## TELEMETRY

The 555 module provides the user with the option of full telemetry facilities via the optional communications software. The module can be either connected to the PC using the 810 interface or via a suitable modem (*Optional: Remote Communications output version only*).

The PC software is MS-Windows™ based and allows the operator to control the module from a remote location.

The remote operator can also view the instrumentation, Alarm and Data log details, and the relay and input status.

All access is password controlled so unauthorised operators cannot log onto the system.

Additionally in the event of the module detecting an alarm condition, it will initiate a modem dial out to the host PC to inform the remote operator of the problem, giving identification of the module followed by the alarm event and the time and date of occurrence. (*Optional: Remote Communications output version only*).

If using a GSM modem, the module is also able to send text messages to a GSM cell phone to indicate gen-set, site and alarm condition.



### NOTE

An Automatic Start version of the 555 is also available (Model 550). Please refer to Deep Sea Electronics for details

## EVENT CAPTURE

The standard module features **event capture facilities**, this records the last 25 shutdown alarms allowing the operator to view the recent operating history of the module to assist in fault finding, etc.



Event Log:

19 Apr2000 14:34:14

**LOW OIL PRESSURE**

## CONFIGURATION

PC based configuration software allows for fast, simple and secure configuration of module parameters. Utilising the P810 interface to provide a safe isolated link to the PC, changes can easily be made to the system by authorised personnel. Access is PIN number protected.

Complex configurations can be saved and loaded from disk or output to a printer for reference. Diagnostic facilities allow for fault finding and monitoring during test and installation.

## BUILT-IN FUNCTIONS

- Alternator Under/Over Volts Warning/Shutdown
- Alternator Under/Over Freq. Warning/Shutdown
- Under/Over Speed Warning/Shutdown
- Low Oil Pressure Warning/Shutdown
- High Engine Temp Warning/Shutdown
- High/Low Battery Volts Warning
- Over-current Warning/Electrical Trip/Shutdown
- Reverse Power Electrical Trip/Shutdown (Option)
- Phase Sequence Electrical Trip/Shutdown (Option)
- Earth Fault Shutdown (Option)
- Short Circuit Fault Electrical Trip/Shutdown

- Adjustable crank cycle/attempts
- Maintenance Due Alarm facility
- External remote start input (On load/Off load)
- Built-in exercise scheduler function
- Magnetic Pick-up or Alternator speed monitoring
- Synchroscope with Auto-sync output (*Option*)
- Full Remote Control and Telemetry (*Option*)
- Engine Instrumentation
- Alternator Output Instrumentation
- 9 Digital inputs - Fully user configurable
- 4 Configurable relay outputs (100+ Control functions)
- LCD Back-lighting for low light level operation
- Security via PIN Number restricted access
- SMS messaging capability with suitable GSM Modem
- Load switching control push-button inputs
- Mains Under/Over Volts detection
- Mains Under/Over Frequency detection
- Change-over contactor control
- Limited configuration from front panel - including user language selection
- Graphic LCD Display for true Multi-lingual use
- Multi-lingual capability - 4 default languages.

## SYNCHRONISING AND LOAD CONTROL OPTIONS

- > **Sync check**
- > **Governor/engine speed control**
- > **AVR/voltage control**
- > **Dead bus sensing**
- > **Synchroscope**
  
- > **No break change-over**
- > **Parallel running with the mains**
- > **KW/kVA<sub>r</sub> load control with mains**
  
- > **P120 analogue governor interface**
- > **P121 analogue AVR interface**
- > **P122 Digital resistance interface**

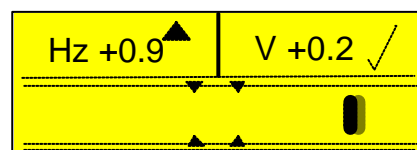

## ENVIRONMENTAL TESTING STANDARDS

**Electromagnetic Compatibility**  
BS EN 50081-2 EMC *Emission Standard for the Industrial Environment*

BS EN 50082-2 EMC *Immunity Standard for the Industrial Environment*

### Vibration

BS EN 60068-2-6 Ten sweeps (up and back down) at 1 octave/minute in each of the three major axes.

5Hz to 8 Hz @ +/-7.5mm constant displacement.

8Hz to 500 Hz @ 2gn constant acceleration

### Temperature

Cold:

BS EN 60068-2-1 to -30°C

Hot:

BS EN 60068-2-2 to 70°C

### Humidity

BS EN 2011 part 2.1 93% RH @ 40°C for 48 hours

### Shock

BS EN 60068-2-27 Three half sine shocks in each of the three major axes 15gn amplitude. 11mS duration.

### Electrical Safety

BS EN 60950 Low Voltage Directive/Safety of information technology equipment, including electrical business equipment.

# CASE DIMENSIONS

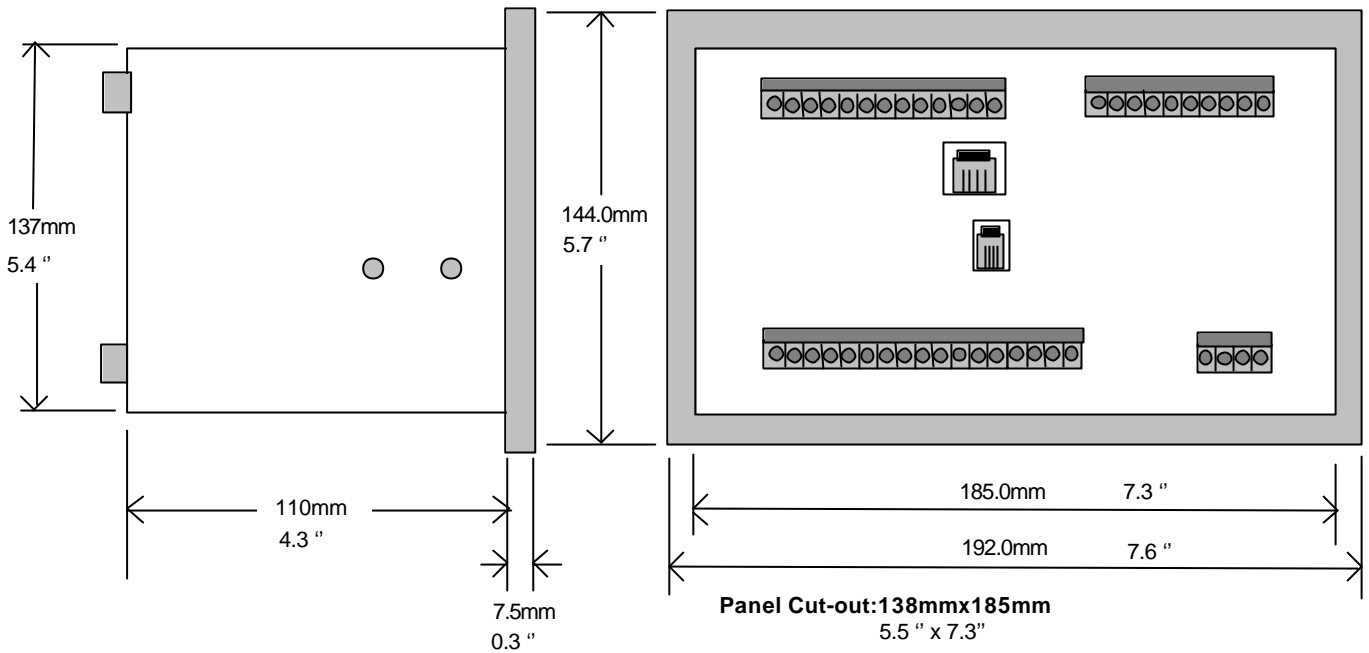

# TYPICAL CONNECTIONS

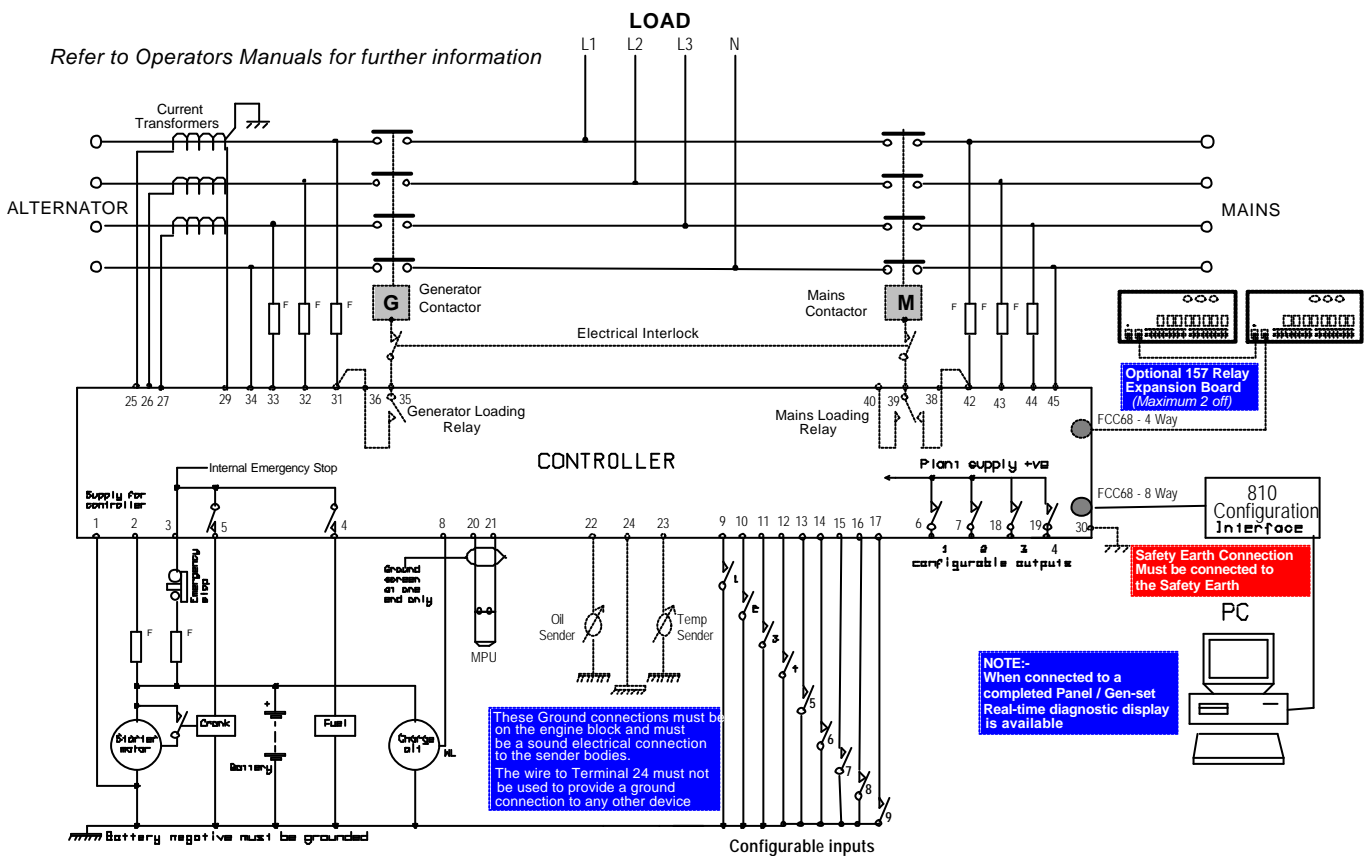

**Deep Sea Electronics Plc.**  
 Highfield House, Hunmanby Industrial Estate,  
 North Yorkshire. YO14 0PH. ENGLAND  
 Tel +44 (0)1723 890099.  
 Fax +44 (0)1723 893303.  
 Email - sales@deepseapl.com  
 Web - www.deepseapl.com

**Deep Sea Electronics inc.**  
 5301 E. State St. – Suite 202  
 Rockford, Illinois 61108 U.S.A.  
 Phone +1 (815) 316-8706  
 Fax +1 (815) 316-8708  
 Email – dsesales@deepseausa.com  
 Web – www.deepseausa.com