

DEEP SEA ELECTRONICS PLC

Highfield House
Hunmanby Industrial Estate
Hunmanby, North Yorkshire
YO14 0PH England

TELEPHONE

+44 (0)1723 890099

FACSIMILE

+44 (0)1723 893303

EMAIL

sales@deepseapl.com

WEBSITE

www.deepseapl.com



Registered in England & Wales No.01319649

VAT No.316923457

DEEP SEA ELECTRONICS INC

3230 Williams Avenue
Rockford
IL 61101-2668 USA

TELEPHONE

+1 (815) 316 8706

FACSIMILE

+1 (815) 316 8708

EMAIL

sales@deepseausa.com

WEBSITE

www.deepseausa.com

YOUR LOCAL DISTRIBUTOR.



DEEP SEA ELECTRONICS PLC maintains a policy of continuous development and reserves the right to change the details shown on this data sheet without prior notice. The contents are intended for guidance only.

This data sheet is printed on 9lives 55 Silk, which is produced with 55% recycled fibre from both pre and post-consumer sources, together with 45% virgin ECF fibre.



DSEMARINE[®] ON-BOARD WITH CONFIDENCE.



DSE5510M

AUTO & MANUAL START CONTROL MODULE (ELECTRONIC ENGINE ENABLED)



The DSE5510M is an Automatic Engine Control Module, designed to provide advanced load share functionality for diesel and gas generating sets that include non-electronic and electronic engines. The module also provides excellent engine monitoring and protection features.

The modules load share functions include, automatic synchronising with built in synchroscope and closing onto dead bus. Direct and flexible outputs from the module are provided to allow connection to the most commonly used speed governors and automatic voltage regulators (AVRs).

The module has been designed to combine a maximum of 16 generators and 16 mains (utility) supplies up to a maximum of 20 in one system, e.g. 16 generators and 4 mains (utility) supplies (DSE5560 required to synchronise with the mains).

The module has the ability to monitor under/over generator volts, over current, under/over generator frequency, under speed, over speed, charge fail, emergency stop, low oil pressure, high engine temperature, fail to start, low/high DC battery volts, fail to stop,

generator short circuit protection, reverse power, generator phase rotation error, earth fault protection, loss of speed signal, fail to open, fail to close, out of sync, MPU open circuit failure, negative phase sequence and loss of excitation.

FEATURES

- Electronic engine capability
- RS232 or RS485 remote communications
- Modbus RTU
- Pin number protected front panel programming
- Engine exercise timer
- Back-lit LCD 4-line text display
- Multiple display languages
- Voltage measurement
- Configurable inputs (9)
- Configurable outputs (5)
- Automatic start
- Manual start
- Audible alarm
- LED indicators
- Built-in governor and AVR control
- Engine history event log
- Engine protection
- Fault condition notification to a designated PC
- Front panel mounting
- PC configuration
- Bus failure detection
- Configurable alarm timers
- Configurable start & stop timers
- Automatic load transfer
- SMS alert messaging
- Front panel mounting
- Remote monitoring

- Magnetic pick-up

LOAD SHARE FEATURES

- ROCOF & vector shift
- Automatic starting & stopping of generator on load demand
- Automatic hours run balancing of generator sets
- Dead bus sensing
- Module has the ability to interface with existing load share lines
- Direct communication from the module to the governor and AVR
- Link up to 16 generators
- Volts & frequency matching
- KW and Kvar load sharing with multiple generators

BENEFITS

- Sends SMS messages to engineers to notify specific engine problems (GSM Modem and SIM card required)
- On-site and remote module configuration
- In-built engine diagnostics removes the requirement for service equipment
- Full engine protection & instrumentation without the need for additional senders (Electronic engines only)
- Remote monitoring of the module using comprehensive DSE PC software
- License free PC software

SPECIFICATION

DC SUPPLY

8V to 35V continuous

CRANKING DROPOUTS

Able to survive 0V for 50mS, providing supply was at least 10V before dropout and supply recovers to 5V. This is achieved without the need for internal batteries

MAXIMUM OPERATING CURRENT

460mA at 12V. 245mA at 24V

MAXIMUM STANDBY CURRENT

375mA at 12V. 200mA at 24V

ALTERNATOR INPUT RANGE

15V(L-N) to 333V AC (L-N) absolute maximum

ALTERNATOR INPUT FREQUENCY

50Hz - 60Hz at rated engine speed (Minimum: 15V AC L-N)

MAGNETIC PICK-UP VOLTAGE RANGE

+/- 0.5V to 70V Peak

MAGNETIC INPUT FREQUENCY

10,000 Hz (max)

START RELAY OUTPUT

16A DC at supply voltage

FUEL RELAY OUTPUT

16A DC at supply voltage

AUXILIARY RELAY OUTPUTS

Three outputs 5A DC at supply voltage
Two outputs volt free 8A at 250V AC

DIMENSIONS

240mm x 172mm x 57mm
9.4" x 6.8" x 2.2"

PANEL CUTOUT

220mm x 160mm
8.7" x 6.3"

CHARGE FAIL/EXCITATION RANGE

0V to 35V

BUILT IN GOVERNOR CONTROL

Fully Isolated
Minimum Load Impedence: 1000Ω
Gain Volts 0V - 10V DC
Offset Volts + / - 10V DC

BUILT IN AVR CONTROL

Fully Isolated
Minimum Load Impedence: 1000Ω
Gain Volts 0V - 10V DC
Offset Volts + / - 10V DC

ENCLOSURE PROTECTION

(front of module)
IP55 (with optional gasket)
IP42 (without gasket)

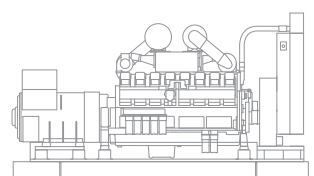

ELECTRONIC ENGINE CAPABILITY

ENVIRONMENTAL TESTING STANDARDS

ELECTRO MAGNETIC CAPABILITY

BS EN 61000-6-2
EMC Generic Emission Standard for the Industrial Environment
BS EN 61000-6-4
EMC Generic Emission Standard for the Industrial Environment

ELECTRICAL SAFETY

BS EN 60950
Safety of Information Technology Equipment, including Electrical Business Equipment

TEMPERATURE

BS EN 60068-2-2
Test Ab to +70°C 60067-2-2 Hot
Test Ab to -30°C 60068-2-1 Cold

VIBRATION

BS EN 60068-2-6
Ten sweeps in each of three major axes
5Hz to 8Hz @ +/-7.5mm, 8Hz to 500Hz @ 2gn

HUMIDITY

BS 2011 part 2.1 60068-2-30
Test Cb Ob Cyclic
93% RH @ 40°C for 48 hours

SHOCK

BS EN 60068-2-27
Three shocks in each of three major axes
15gn in 11ms

TYPICAL LOAD SHARE APPLICATION

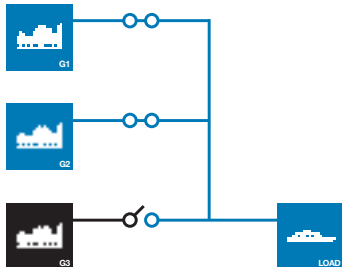

OPERATION

The module is operated using the front STOP/RESET, MANUAL, AUTO and START push buttons. Three of these push buttons include an LED indicator. Additional push buttons provide LCD display scroll, lamp test, mute functionality and breaker control.

TIMERS & INPUT FUNCTIONS

The module has been designed to include the following timers and input functions:

- Start delay timer
- Stop delay timer
- Crank timer
- Crank rest timer
- Engage attempt & manual crank limit timers
- Safety on delay timer
- Warm up timer
- Cooling timer
- Energise to stop hold timer
- Pre-heat timer
- Pre-heat bypass timer
- Smoke limiting control timer
- Fail to stop timer
- Over speed over shoot timer
- Breaker pulse control timers
- DC battery alarm delay timers
- Sync/fail to sync timer

BUILT-IN FUNCTIONS

- Alternator under/over volts
- Alternator under/over frequency
- Warning or shutdown on engine temperature, over/under speed, oil pressure
- Warning, shutdown or electrical trip on battery volts or over current
- Shutdown or electrical trip on reverse power, phase rotation or short circuit fault
- Earth fault shutdown
- Adjustable crank cycle/attempts
- Full remote control and telemetry
- 9 configurable digital inputs
- 5 configurable and 2 fixed relay outputs
- System lock input
- Load switching control push-button inputs
- RCOF/vector shift (mains/utility decoupling)
- Negative phase sequence
- Loss of excitation

INSTRUMENTATION AND ALARMS

The DSE5510M module provides advanced metering and alarm functionality via the LCD display. The information can be accessed using the display scroll push buttons. The table below shows the instrumentation and alarm features the module provides.

Generator Volts L1-N, L2-N, L3-N
Generator Volts L1-L2, L2-L3, L3-L1
Generator Amps L1, L2, L3
Generator Frequency Hz
Generator kVA L1, L2, L3, Total
Generator kW L1, L2, L3, Total
Generator pf L1, L2, L3, Average
Generator kVAh L1, L2, L3, Total
Generator KWh
Generator KVAh
Generator KVAh
Generator Phase Sequence
Synchroscope Display
Engine Speed RPM
Engine Oil Pressure
Engine Temperature
Plant Battery Volts
Engine Hours Run
Number of Start Attempts
Maintenance Display
Engine ECU diagnostics information via industry standard CAN interface
Enhanced metering via CAN when connected to an electronic engine

TELEMETRY

The module gives the user full telemetry facilities when using the optional communications software. The module can be connected to a PC using the DSE810 PC interface or by using a suitable modem.

The PC software is Microsoft Windows™ based. All access into the module can be configured to become password protected to prevent unauthorised entry. The PC software allows the module to be controlled from a remote location.

COMMUNICATIONS

The DSE5510M has a number of different communication capabilities.

SMS Messaging

When the module detects an alarm condition, it has the ability to send an SMS message to a dedicated mobile number, notifying an engineer of the problem. (GSM Modem and SIM Card required).

Remote Communications

When the module detects an alarm condition, it dials out to a PC notifying the user of the exact alarm condition.

Vessel Management

The module has been designed to be integrated into new and existing vessel management systems.

PC Software

The module has the ability to be configured and monitored from a remote PC, using the DSE810 interface (modem required).

EVENT LOG

The module includes a comprehensive event log that shows the 25 most recent alarm conditions and the date and time that they occurred.

This function assists the user when fault finding and maintaining the generating set.

EXPANSION MODULES

DSE123 Load Share Lines Interface Module
DSE157 Relay Input Expansion Module
DSE545 & DSE548 Remote Annunciation Expansion Module
DSE130 Input Expansion Module

ELECTRONIC ENGINE COMPATIBILITY

- Cummins
- Deutz
- John Deere
- MTU
- Perkins
- Scania
- Volvo
- Generac
- Plus additional manufacturers

DSE5510M

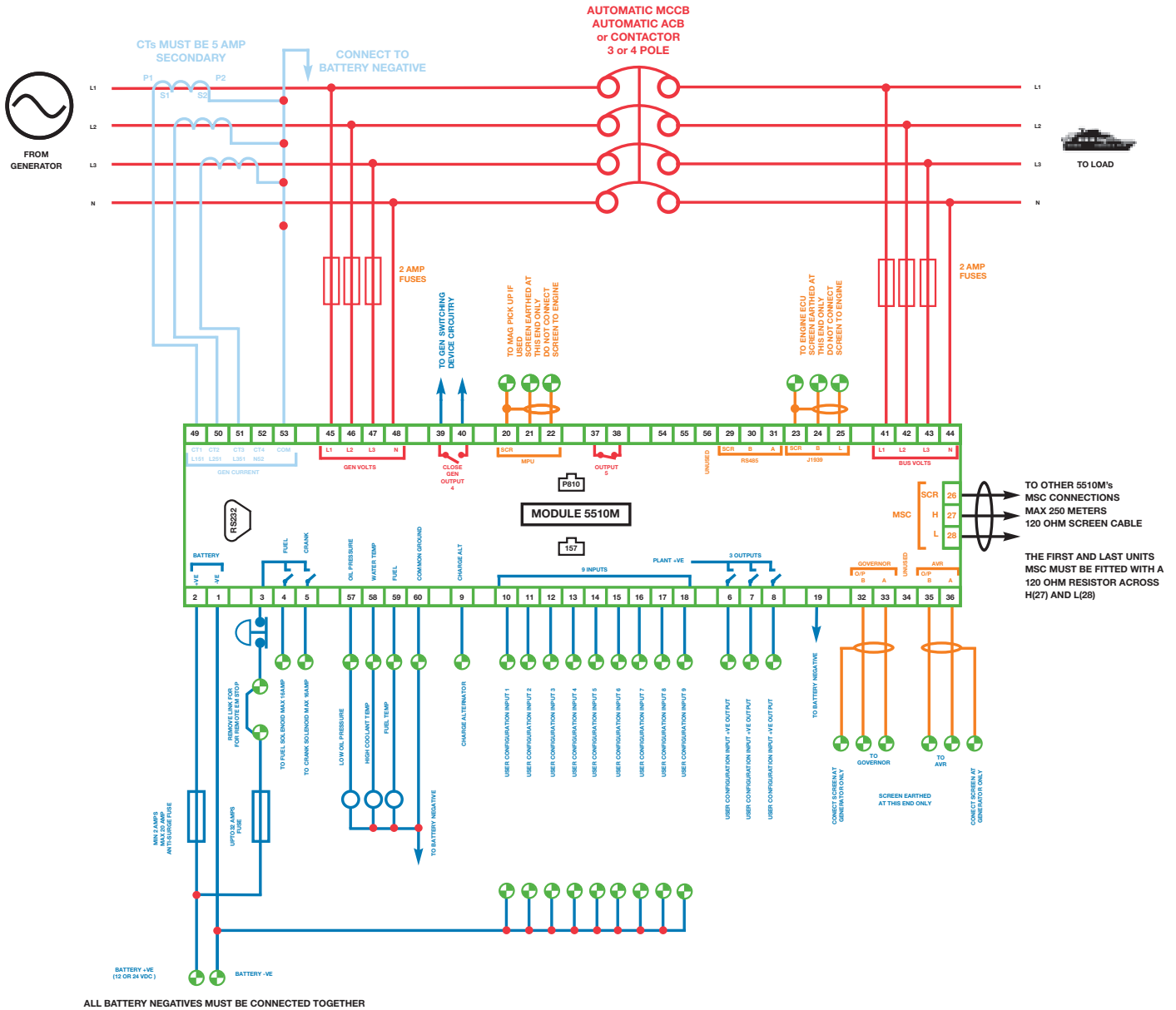

RELATED MATERIALS

TITLE	PART NO'S
DSE5510M Manual	057-080
DSE123 Data Sheet	055-044
Load Share Design & Commissioning Guide to Synchronising and Load Sharing	057-047 057-045/6
55xx Software manual	057-007
CAN & DSE wiring guide	057-004
DSE5510M Installation Instructions	053-048