

020-130

GPS ANTENNA

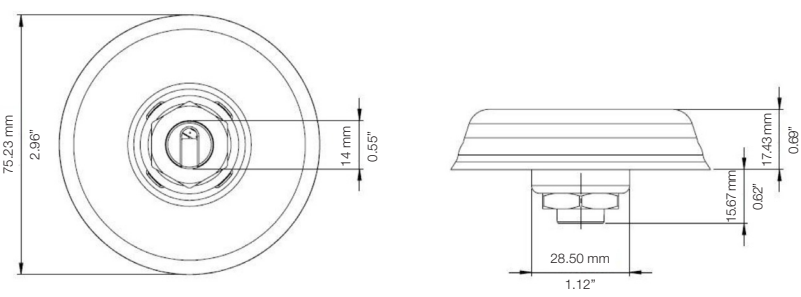

TYPE	GPS Antenna	
FREQUENCIES	GPS (L1/1575.42 MHz)	
MOUNTING	Body mounting	
IMPEDANCE	50 Ω	
POLARISATION	RHCP	
GAIN	26 dB @ 3V / 28 dB @ 5V	
VSWR	<1.5:1	
PROTECTION	IP67/IP69K/IK09	
OPERATING TEMPERATURE	-40 °C to +85 °C -40 °F to +185 °F	
MATERIAL	Housing – ABS Base – Zamak	
MAXIMUM DIMENSIONS	<p>Diameter 75.23 mm 2.96"</p> <p>Housing depth 17.43 mm 0.69"</p> <p>Bolt depth 15.67 mm 0.62"</p>	
WEIGHT (Based on default cable length & connector)	200 g 7.05 oz	
COLOUR	Black	

